

Features

- Built-in 100v/70v transformer
- Waterproof projector type loudspeaker
- 2x6" full range speaker unit
- IP6 waterproof level
- Power taps 5w-10w-20w @100V
- Aluminum enclosure and metal bracket

Description

The **P-311** is a dual-directional waterproof projection speaker built-in 70v/100v transformer. The 70v/100v transformer technique reduces line losses on longer distance and allows easy parallel connection of multiple loudspeakers.

The built-in two 6" full range speaker drivers are designed of wide frequency response 110-15kHz, the multiple power taps 5W, 10W & 20W are helpful for different applications varies from room size and ambient noise surroundings.

The aluminum enclosure and metal bracket are of white color. Easy and secure wall mount installation through the supplied mounting bracket.

It is ideal choice for industrial and commercial applications in the outdoor area of train station, shopping mall, parking area and factory where background music and paging is needed.



Specification

| Model | P-311 |
|----------------------------|---|
| Power Taps @100V | 5W, 10W, 20W |
| Power Taps @70V | 2.5W, 5W, 10W |
| Impedance | Blue: Com Green: 2 K Ω Yellow: 1K Ω Red: 500 Ω |
| SPL(1W/1M) | 92dB |
| Max. SPL (Rated W/1M) | 105dB |
| Frequency Response (-10dB) | 110-15KHz |
| Finish | Baffle: Aluminum, White Grille: Steel, White |
| Speaker Driver | 6"x2 |
| Dimensions | 172 x 252mm |
| Weight | 3.3Kg |
| Mounting | With mounting bracket fixed by screw |

Appearance:

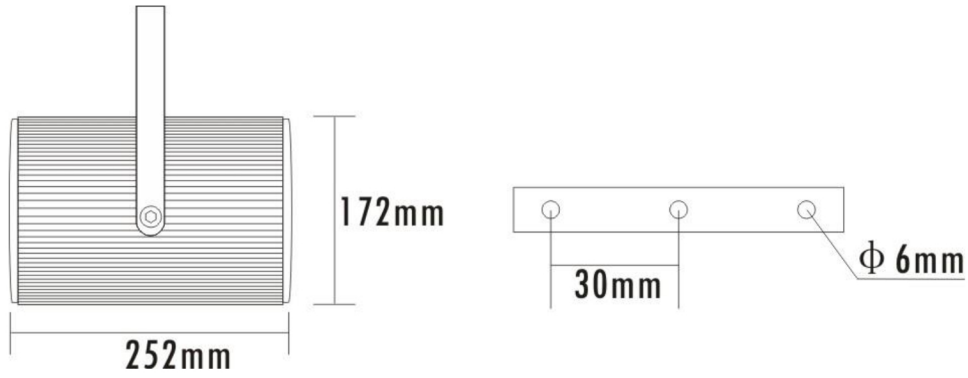

Direction Diagram:

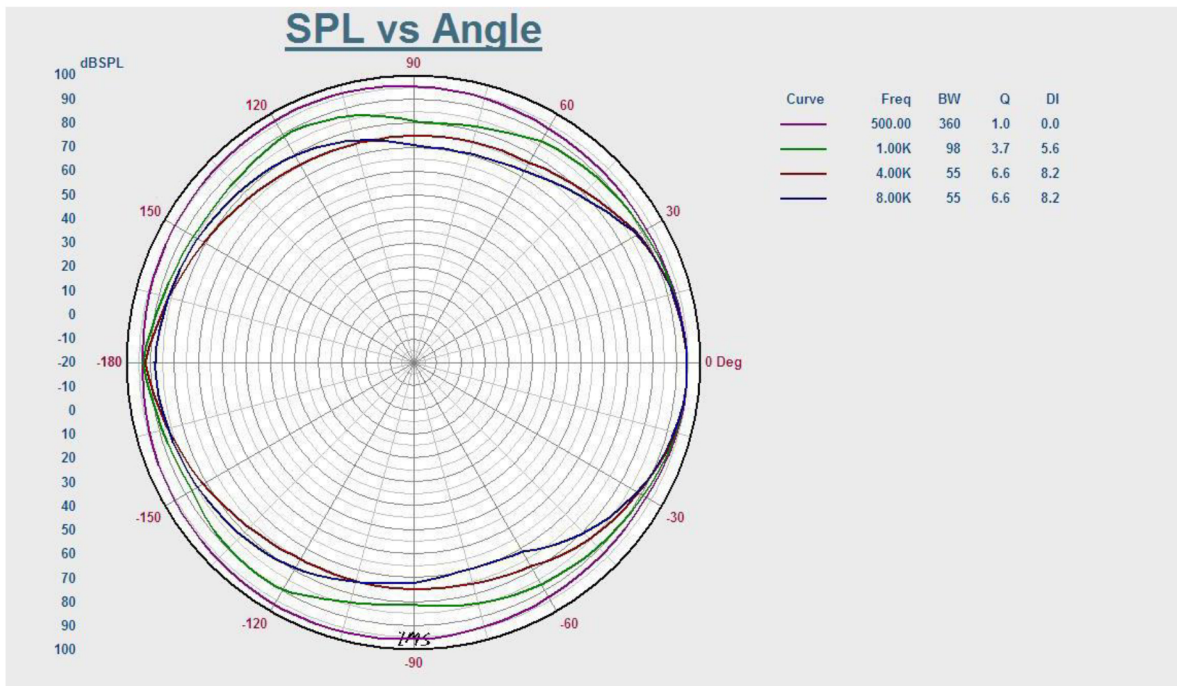

Frequency Response:

