

CADC600PI-V

www.black.honeywell.com

600TVL HIGH RESOLUTION VANDALPROOF IR FIXED DOME CAMERA

Honeywell Vista series CADC600PI-V vandalproof IR fixed dome camera is designed for commercial and residential surveillance, and is ideal for indoor or outdoor applications. Featuring a high resolution with 600TVL with outstanding image sharpness, up to 15m IR visible range, anti-flare double glass and intelligent IR, the CADC600PI-V is most suitable for night time and dim environment surveillance.

Installation is quick and easy. The CADC600PI-V comes completely assembled and ready-to-use to maximize installation flexibility – the camera fits perfectly in any locations on ceiling, wall and covert corner.

Market Opportunities

The CADC600PI-V is a vandalproof IR dome camera which can be widely used in mid-scale indoor and outdoor sites. It is a peace of mind security tool for property owners to protect their residential apartment, commercial buildings, retail stores, offices, warehouses, shopping malls and clinics.

FEATURES

- High resolution 600TVL images
- Optional 3.6 / 6 / 8 mm Fixed Lens
- 10 - 15m IR Visible Range
- 0.1 Lux (IR LED OFF) / 0 Lux (IR LED ON)
- Anti-flare Double Glass
- Intelligent IR Compensation
- IP66
- 12 VDC Input Voltage



CADC600PI-V

www.black.honeywell.com

600TVL HIGH RESOLUTION VANDALPROOF IR FIXED DOME CAMERA

SPECIFICATIONS

Model	CADC600PI-V	CADC600NI-V
Image Sensor	1/3" SONY Super HAD II CCD	
Signal System	PAL	NTSC
Effective Pixels	752(H) x 582(V)	768(H) x 494(V)
Horizontal Resolution	Color 600TVL; B/W 650TVL	
Lens	Fixed Lens f=3.6 / 6 / 8 selectable	
IR LED	850nm, 24pcs IR LED	
IR Beam Distance	10 - 15m	
Minimum Illumination	0.1 Lux (IR LED OFF) / 0 Lux (IR LED ON)	
S/N Ratio	More than 52dB	
AES	1/50 - 1/100,000 sec	1/60 - 1/100,000 sec
White Balance	Auto	
AGC	Auto	
BLC	Auto	
Gamma Correction	0.45	
Sync Mode	Internal	
Video Output	1.0 Vp-p, 75 Ohm	
Input Voltage	12VDC	
Current Consumption	100 mA (IR LED OFF) + 200 mA (IR LED ON)	
Operation Temperature	-10°C to +50°C under 90%RH (non-condensing)	
Rating	IP66	
Dimension	94 (D) x 80 (H) mm	
Weight	400g	
Certificate	CE, FCC, C-tick	

Note: Honeywell reserves the right, without notification, to make changes in product design or specifications.

CADC600PI-V

www.black.honeywell.com

600TVL HIGH RESOLUTION VANDALPROOF IR FIXED DOME CAMERA

DIMENSION

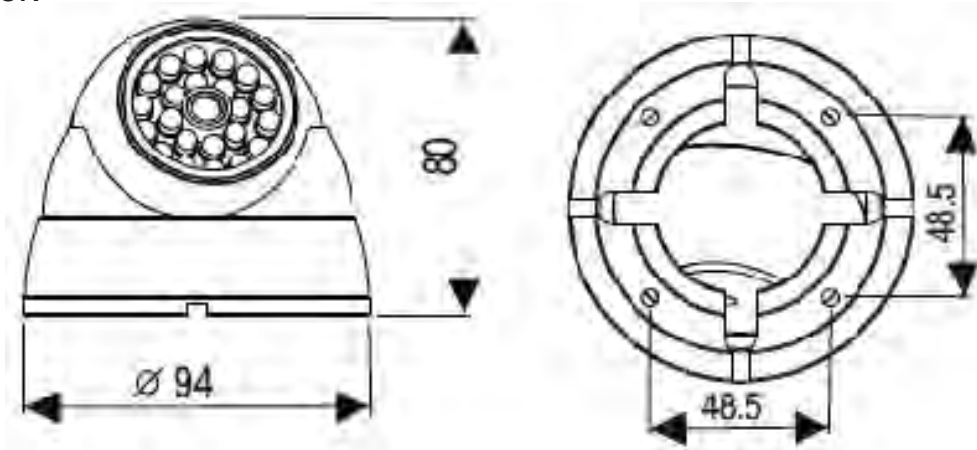

unit: mm

ORDERING

3.6mm Fixed Lens	
CADC600PI-V36	Vandalproof IR fixed dome, 600TVL, 0 Lux (IR LED ON), Day/Night, 12 VDC, 3.6mm, IR distance 10 - 15m, PAL
CADC600NI-V36	Vandalproof IR fixed dome, 600TVL, 0 Lux (IR LED ON), Day/Night, 12 VDC, 3.6mm, IR distance 10 - 15m, NTSC
6.0mm Fixed Lens	
CADC600PI-V60	Vandalproof IR fixed dome, 600TVL, 0 Lux (IR LED ON), Day/Night, 12 VDC, 6.0mm, IR distance 10 - 15m, PAL
CADC600NI-V60	Vandalproof IR fixed dome, 600TVL, 0 Lux (IR LED ON), Day/Night, 12 VDC, 6.0mm, IR distance 10 - 15m, NTSC
8.0mm Fixed Lens	
CADC600PI-V80	Vandalproof IR fixed dome, 600TVL, 0 Lux (IR LED ON), Day/Night, 12 VDC, 8.0mm, IR distance 10 - 15m, PAL
CADC600NI-V80	Vandalproof IR fixed dome, 600TVL, 0 Lux (IR LED ON), Day/Night, 12 VDC, 8.0mm, IR distance 10 - 15m, NTSC

CADC600PI-V

www.black.honeywell.com

600TVL HIGH RESOLUTION VANDALPROOF IR FIXED DOME CAMERA

For more information:

Security Hong Kong
Security Australia National Sales Hotline
Security India

Tel: (852) 2405 2323
Tel: 1300 765 532
Tel: (91) 124 4029800

www.black.honeywell.com
security.black@honeywell.com

Honeywell Security Group
Automation & Control Solutions
Honeywell International Inc.
www.security.honeywell.com

Aug 2012
© 2012 Honeywell International Inc.

VISTA
Honeywell