

FlexGuard® FG-1625TAS Glassbreak Detector Installation Instructions

Refer to Supplemental Information (next page) for complete descriptions of these installation steps

FG-1625TAS Glassbreak Detector

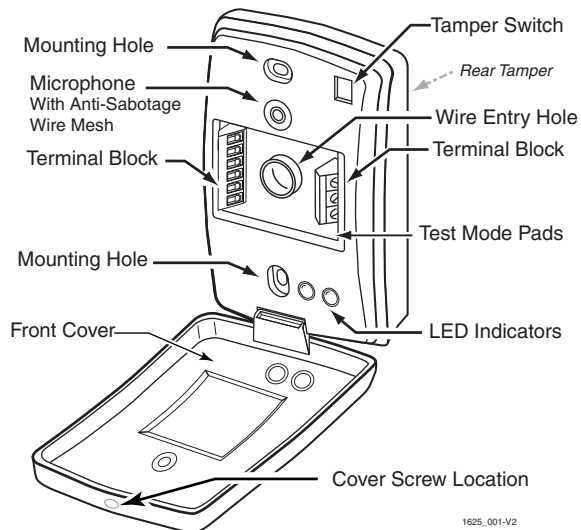

Select Mounting Location

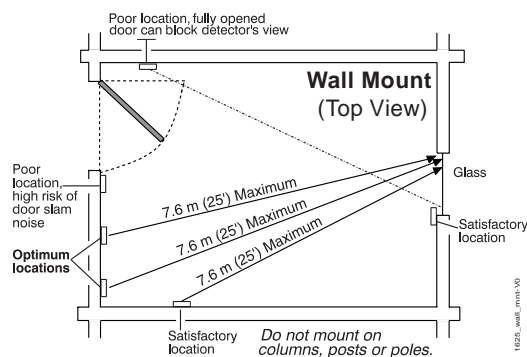

Test Location w/ 9V Battery

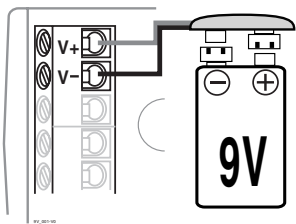

Set Sensitivity & LED Configuration

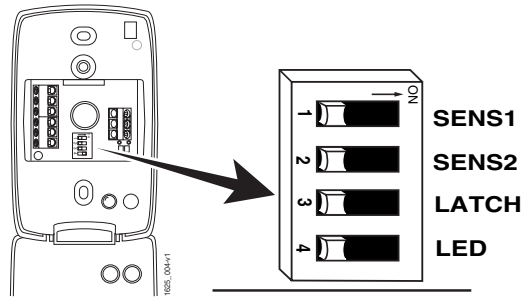

SENS1 & SENS2 configure sensitivity

SENSITIVITY	APPROXIMATE RANGE	SENS1	SENS2
MAX	7.6m (25 ft)	OFF	OFF
MEDIUM	4.6m (15 ft)	ON	OFF
LOW	3m (10 ft)	OFF	ON
LOWEST	1.5m (5 ft)	ON	ON

NOTE: Ranges are approximate and vary with each room's acoustic properties. Always verify range with a FG-701 Glassbreak Simulator.

The LATCH and LED DIP switches configure LED indicator behavior.

SWITCH	OFF	ON
LATCH	Red LED lights for 5 seconds during alarm	Red LED latches ON when detector goes into alarm ^{1,2}
LED	LEDs disabled (except for power up and test mode ³)	LEDs always enabled

¹ The timing of the alarm relay is not affected by the latched Alarm LED.

² Reset the Alarm LED by removing/restoring power, or by toggling the detector in and out of Test Mode.

³ LEDs can be enabled/disabled using FG-701.

Enable Wall Tamper

- Remove plastic tab from rear of detector.
- Install wall tamper screw as shown.
- Set screw depth to make contact w/ bottom of tamper cavity when device is installed

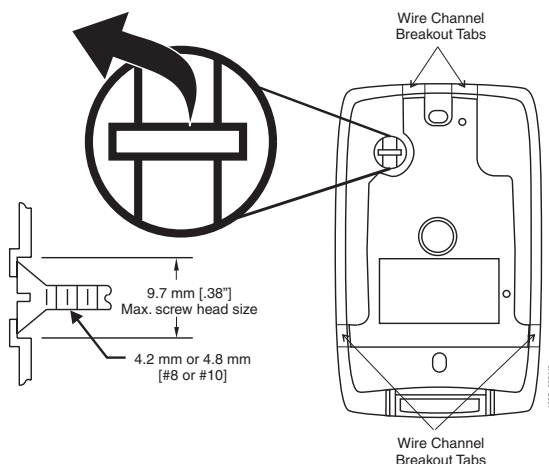

Connect Detector

Connect detector using 18 to 22 AWG wire, with ends stripped approximately 6mm (1/4 in.) Use the appropriate wiring method as shown in these diagrams:

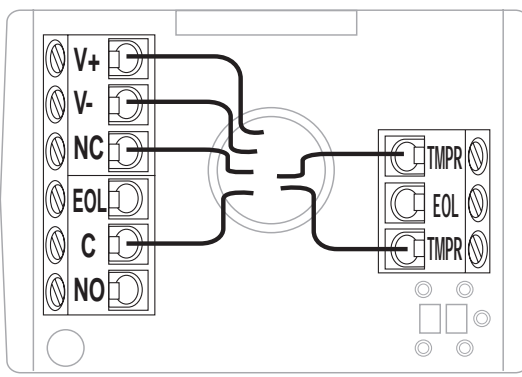

Normally Closed Loop/No EOL Resistor

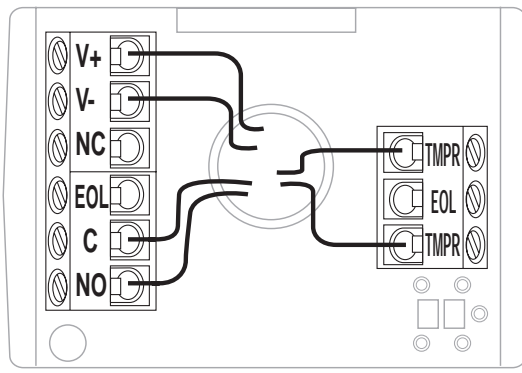

Normally Open Loop/No EOL Resistor

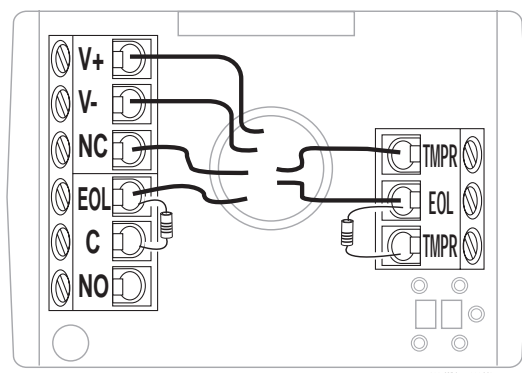

Normally Closed Loop/With EOL Resistor

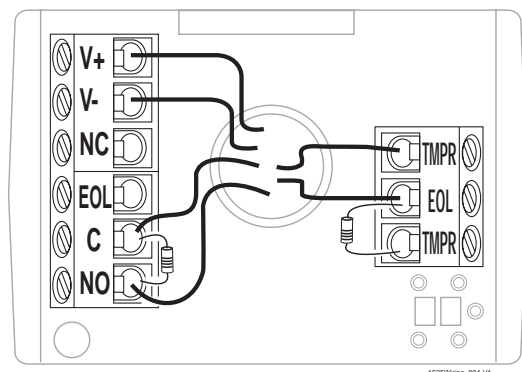

Normally Open Loop/With EOL Resistor

Mount Detector

- Place unit over wall tamper screw, if used!
- Use mounting holes as template to mark ceiling or wall.
- Mount detector using appropriate hardware.

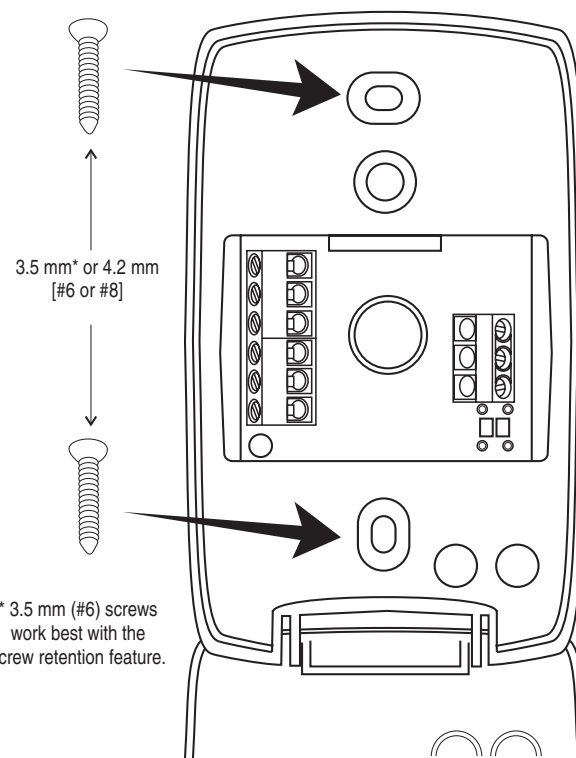

* 3.5 mm (#6) screws work best with the screw retention feature.

Test Detector Installation

Enter Test Mode using FG-701 (see Testing the Detector on the next page) or manually by shorting the Test Mode pads (as below).

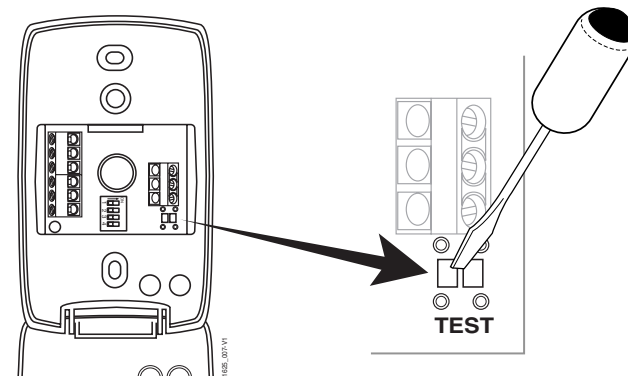

Install Cover Screw (optional)

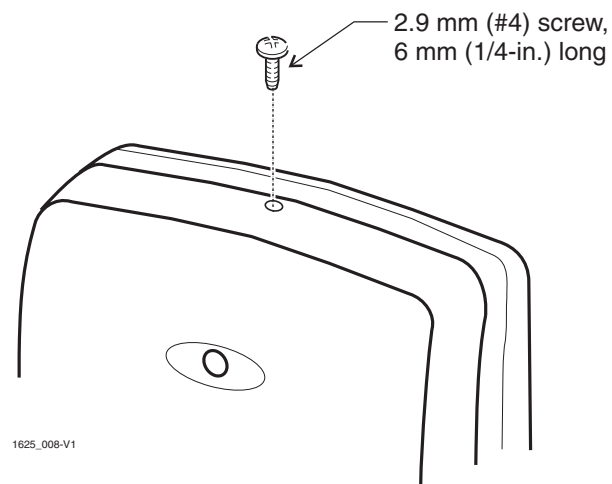

FlexGuard® FG-1625TAS Glassbreak Detector Supplemental Information

Refer to Installation Instructions and diagrams (next page) when installing this product

1. General Information

The FG-1625TAS glassbreak detector senses the sound of breaking plate, tempered, laminated, wired, coated and sealed insulating glass.

This product has a wire mesh disc located in front of the microphone and in plain view. Any attempt to sabotage the microphone will dislodge or damage the disc and provide a visual indication of tampering.

2. Choosing Mounting Location

The preferred mounting location for the device is on a wall or ceiling, opposite the protected glass.

For the best detector performance, select a mounting location that is:

- within 7.6 m (25 feet) of the protected glass;
- within clear view of the protected glass;
- at least 2 m (6.5 feet) from the floor;
- at least 1 m (3.3 feet) from forced air ducts;
- at least 1 m (3.3 feet) from sirens or bells greater than 5 cm (2 inches) in diameter.
- between the protected glass and any heavy window coverings that may be present. Alternatively, when heavy window coverings are present, the detector can be mounted on the frame of the window.

Avoid mounting the detector on the same wall as the protected glass, on free-standing posts or pillars, or in rooms with noisy equipment (air compressors, bells, power tools, etc.), if this equipment is operated when the detector is armed.

3. Testing Mounting Location With 9V Battery

You may test the detector in the desired mounting location before drilling/wiring. *If the 9V battery cannot supply sufficient power, the detector will not operate and the red and green LEDs will flash on/off.*

Follow the procedure described in "Testing the Detector" (next column) to confirm proper operation.

4. Configuring Sensitivity (Range)

DIP switches SENS1 and SENS2 set detector sensitivity (range), as shown:

SENSITIVITY	RANGE *	SENS1	SENS2
MAX	7.6m (25 ft)	OFF	OFF
MEDIUM	4.6m (15 ft)	ON	OFF
LOW	3m (10 ft)	OFF	ON
LOWEST	1.5m (5 ft)	ON	ON

*Sensitivity must be set to match the distance between the detector and the protected glass, as verified using the FG-701 Glassbreak Simulator.

5. Configuring LED Switch

The LATCH and LED DIP switches determine LED indicator operation.

SWITCH	OFF	ON
LATCH	Red LED lights for 5 seconds during alarm	Red LED latches ON when detector goes into alarm ^{1,2}
LED	LEDs disabled (except for power up and test mode ³)	LEDs always enabled

¹ Alarm relay timing is not affected by the latched Alarm LED.

² Reset the Alarm LED by removing/restoring power, or by toggling the detector in and out of Test Mode.

³ LEDs can be enabled/disabled using FG-701.

6. Enabling Optional Rear Tamper

The FG-1625TAS is equipped with a combination normally-closed (NC) cover and wall tamper switches. Each unit is shipped with the cover tamper operational, and the wall tamper disabled.

To enable the rear tamper, remove the plastic tab on the back of the detector, using needle-nose pliers. The wall tamper arm will then extend through the hole. *Proceed with the following mounting instructions to install the wall tamper screw.*

7. Mounting the Detector

NOTE: If ceiling mounted, the end with the hole (micro-phone end) should face the glass being protected.

1. **If using optional Wall Tamper:** Mark the mounting location for the wall tamper screw based on the final location of the detector. Then, install the wall tamper screw so that it will just make contact with the bottom of the tamper cavity when the unit is mounted. *Use a flat head 4.2 mm or 4.8 mm screw (#8 or #10).*
2. Position the unit over the wall tamper screw (if used), then mark the mounting screw and wire openings. *If required by the location, install wall anchors for the mounting screws.*

3. Secure the unit to the wall or ceiling, oriented so the microphone has the best line of sight to the protected glass.

8. Wiring the Detector

Refer to the wiring diagrams (page 1) to select the appropriate wiring configuration.

9. Testing the Detector

The detector should be tested at least once each year. Test the detector with the FG-701 Glassbreak Simulator. The model FG-700 Glassbreak Simulator can also be used if it is set for the TEMPered glass sound. Other simulators will not give accurate indication of range.

To enter Test Mode manually:

1. Open the front cover.
2. Use a screwdriver to short the Test Mode pads on the PC board (see diagram on next page).
3. Close the front cover.

The detector's green LED blinks approximately once per second to indicate that it has entered Test Mode.

To enter the Test Mode with the FG-701:

1. Stand within 4.6 m (15 feet) of the detector.
2. Switch the FG-701 to ACTIVATE and MANuAl modes.
3. Point the front speaker of the glassbreak simulator towards the detector. Press the red START button to send a short activation code.

When the detector enters Test Mode, the green LED on the detector flashes about once per second. If the green LED does not flash, move closer to the detector and repeat the procedure.

Testing the Detector (flex and audio signals):

To test the FG-1625TAS, do the following:

1. Place the detector in Test Mode.
2. Set the FG-701 switches to the TEST and FLEX positions.
3. Position the FG-701 near the farthest point of the protected glass, and point the speaker directly at the detector. If window coverings are present, close them fully and hold the FG-701 between the coverings and the protected glass.
4. Press the red START button. The simulator clicks on and starts an 8-second armed period.
5. Generate a flex signal by carefully striking the glass with a cushioned tool. The FG-701 responds with a burst of glassbreak audio.

If the detector receives both the flex and audio signals properly, its red Alarm LED lights. (Red Alarm LED does not latch in Test Mode).

Testing the Detector (audio signals only):

The FG-701 can also be used to test the detector's ability to receive audio signals only. See the FG-701 Operating Instructions for additional information. When it receives the audio signal, the detector flickers its green Event LED.

Exiting Test Mode:

When you have finished testing, exit Test Mode by following the same procedure used to enter Test Mode. The FG-1625TAS will automatically exit Test Mode five minutes after the last event is detected.

10. LED Indicators

The detector is equipped with two LEDs: a green Event LED and a red Alarm LED. When the LEDs are enabled, they light in a variety of patterns to convey the detector's operational status. The following table summarizes the LED messages.

CONDITION	GREEN LED	RED LED
Normal	OFF	OFF
Normal, event detected	Flicker	OFF
Normal, break detected	OFF	ON 5 seconds
Normal, alarm latched	OFF	ON
Power up	ON 1 second	ON 1 second
Low Voltage	Flash ON/OFF	Flash ON/OFF
Test Mode	Flash once per sec	OFF
Test Mode, event detected	Flicker	OFF
Test Mode, alarm	Flash once per sec	ON 5 seconds

11. Cover Screw

The front cover can be secured after installation. To do so, remove the cover breakout flash and secure the front cover with a 2.9 mm x 6.0 mm (#4 x 1/4") screw.

12. Remote LED Enable/Disable Mode

The detector's Remote LED Enable/Disable Mode allows you to enable or disable the detector's LEDs with the FG-701 Glassbreak Simulator.

To enable or disable the LEDs with the FG-701 Activation Code:

1. Set LED switch, S4 position 4, to off.
2. Enter Test Mode, and then exit Test Mode.
3. Within two (2) seconds, enter Test Mode again; this changes LED enable/disable status.
4. Clap your hands to test the LEDs. If enabled, the green LED will flicker. If disabled, the green LED will remain off.

13. Nominal Glass Thickness Chart

Glass Type*	Nominal Thickness	
	Minimum	Maximum
Plate	2mm (3/32 in.)	10mm (3/8 in.)
Tempered	3mm (1/8 in.)	10mm (3/8 in.)
Laminated ¹	3mm (1/8 in.)	14mm (9/16 in.)
Wired	6mm (1/4 in.)	6mm (1/4 in.)
Coated ²	3mm (1/8 in.)	6mm (1/4 in.)
Sealed Insulating ^{1,3}	3mm (1/8 in.) [13mm (1/2 in.) overall]	6mm (1/4 in.) [19mm (3/4 in.) overall]

* Minimum size for all types is 28cm (11 in.) square; glass must be framed in the wall or mounted in a barrier at least 0.9m (36 in.) wide.

¹ Protected only if both plates in the unit are broken

² Coated glass with security films up to 0.3mm (12 mils) thick (including films for solar protection) may be used. Film Technologies International, Inc.'s GLASS-GARD GGLL 1200 has been evaluated with this product by Underwriters Laboratories, Inc. at Honeywell's request

³ Maximum range for protecting sealed insulating glass of 6.1m (20 ft.) with sensitivity set at maximum.

14. Specifications

Range:
7.6 m (25 ft.) maximum, omni directional
No minimum range

Operating Temperature:
-10° C to 55° C
(14° F to 131° F)
Storage: -20° C to 55° C
(-4° F to 131° F)

Alarm Duration:
5 seconds (unaffected by alarm LED latching)

Alarm Relay:
Form C
100 mA maximum
25 VDC maximum
ON/closed 22Ω ±6Ω
OFF/open >1MΩ

Tamper Switch:
Combination cover/ wall tamper
25 mA maximum
24 VDC maximum

RFI Immunity:
30 V/m,
10 MHz - 1000 MHz

ESD Immunity:
10 kV discharges of either polarity to exposed surfaces

Power Requirements:
6 - 18 VDC; 12 mA typical at 12 VDC,
22 mA max, (Latched LED)
AC Ripple: 4 Volts peak-to-peak at Nominal 12 VDC

Dimensions:
115 mm x 72 mm x 27 mm
(4.5 in. H x 2.8 in. W x 1.05 in. D)

Weight:
98 g (3.5 oz.)
Packaged Product: 126 g (4.5 oz.)

Approvals / Listings:
FCC verified
IC verified
CE
C-Tick
EN 50131-1
Security Grade 3
Environmental Class II
Suitable for connection to an EN60950 Class II Limited Power Source.

 Customers in European Union countries are advised to dispose of this product, at the end of its useful life, as per applicable local laws, regulations and procedures.

To obtain applicable EU compliance Declaration of Conformities for this product, please refer to our Website <http://www.security.honeywell.com/hscce/international/index.html>. For any additional information regarding the compliance of this product to any EU specific requirements, please contact – Quality Assurance Department, Honeywell Security & Custom Electronics, Newhouse Industrial Estate, Motherwell, Lanarkshire ML1 5SB, Scotland, United Kingdom
Tel: +44(0)1698 738200
Email: UK64Sales@Honeywell.com

NOTICES

FCC NOTICE: This device complies with Part 15 of the FCC Rules. Operation is subject to the following two conditions: (1) This device may not cause harmful interference, and (2) this device must accept any interference received, including interference that may cause undesired operation.

The user is cautioned that changes or modifications not expressly approved by Honeywell could void the user's authority to operate this equipment.

Note: This equipment has been tested and found to comply with the limits for a Class B digital device, pursuant to part 15 of the FCC Rules. These limits are designed to provide reasonable protection against harmful interference in a residential installation. This equipment generates, uses, and can radiate radio frequency energy and, if not installed and used in accordance with the instructions, may cause harmful interference to radio communications. However, there is no guarantee that interference will not occur in a particular installation. If this equipment does cause harmful interference to radio or television reception, which can be determined by turning the equipment off and on, the user is encouraged to try to correct the interference by one or more of the following measures: 1) Reorient or relocate the receiving antenna, 2) Increase the separation between the equipment and receiver, 3) Connect the equipment into an outlet on a circuit different from that to which the receiver is connected. The installer can also consult an experienced radio/television technician for additional suggestions, if necessary.

IC Notice: This Class B digital apparatus complies with the Canadian ICES-003. Cet appareil numérique de la Classe B est conforme à la norme NMB-003 du Canada.