

HB30XD2/HB41XD2

TDN 1080p IR Bullet Camera



HB30XD2



HB41XD2

HD

OPERATIONAL	
VIDEO STANDARD	NTSC/PAL
SCANNING SYSTEM	Progressive scan
IMAGE SENSOR	1/2.9" 2 MP CMOS
NUMBER OF PIXELS (H × V)	1920 × 1080
MINIMUM ILLUMINATION	HB30XD2: 0.02 lux colour @ F2.0, 0 lux B/W with IR LEDs on @ F2.0 HB41XD2: 0.02 lux colour @ F1.4, 0 lux B/W with IR LEDs on @ F1.4
S/N RATIO	> 65 dB
ELECTRONIC SHUTTER SPEED	NTSC: 1/30 – 1/100,000 s PAL: 1/25 – 1/100,000 s
RESOLUTION	1080p (1920 × 1080)
FRAME RATE	25/30 fps @ 1080p 25/30/50/60 fps @ 720p
VIDEO OUTPUT	1-channel BNC CVI/TVI/AHD/CVBS video output
IR DISTANCE	Up to 98 ft. (30 m), depending on scene reflectance
NUMBER OF IR LEDs	HB30XD2: 18 IR LEDs HB41XD2: 20 IR LEDs
SMART IR	Auto/Manual
DAY/NIGHT	Auto (ICR)/Manual
BACKLIGHT COMPENSATION	BLC/HLC/DWDR
WHITE BALANCE	Auto/Manual
GAIN CONTROL	AGC
WIDE DYNAMIC RANGE	DWDR
NOISE REDUCTION	2DNR
PRIVACY MASKING	Up to 8 configurable areas
LENS	HB30XD2: 3.6 mm, fixed lens, F2.0 HB41XD2: 2.7 – 13.5 mm, vari-focal lens, F1.4
HORIZONTAL ANGLE OF VIEW	HB30XD2: 82.8° HB41XD2: 104° ~ 27.5°
AUDIO	N/A

ELECTRICAL	
POWER SUPPLY	12 VDC ±25%
POWER CONSUMPTION	HB30XD2: 2.8 W max. (IR LEDs on) HB41XD2: 2.5 W max. (IR LEDs on)
MECHANICAL	
DIMENSIONS	HB30XD2: 164.8 mm × 69.7 mm × 71.0 mm (6.49" × 2.74" × 2.79") HB41XD2: 214.8 mm × 90.4 mm × 90.4 mm (8.46" × 3.56" × 3.56")
PRODUCT WEIGHT	HB30XD2: 0.77 lb. (0.35 kg) HB41XD2: 1.21 lb. ()
PACKAGE WEIGHT	HB30XD2: 0.48 kg (1.06 lb.) HB41XD2: 0.68 kg (1.50 lb.)
CONSTRUCTION	Die-cast aluminum housing with powder coat
CONSTRUCTION COLOUR	RAL 9003 (White)
ENVIRONMENTAL	
OPERATING TEMPERATURE	-40°C to 60°C (-40°F to 140°F)
COLD START	Startup should be done at above -40°C (-40°F)
STORAGE TEMPERATURE	-40°C to 60°C (-40°F to 140°F)
RELATIVE HUMIDITY	Less than 90%, non-condensing
INGRESS PROTECTION	IP66
REGULATORY	
EMISSIONS	EN55032, ANSI C63.4-2014
IMMUNITY	EN50130-4
SAFETY	EU: EN60950-1
ROHS	EN50581

RECOMMENDED ACCESSORIES

SYSTEM COMPATIBILITY	
HRHQ104* HQA DVRS	4-channel, 720p@120/100 fps, 1080p@60/50 fps, 1 SATA, alarm I/O
HRHQ108* HQA DVRS	8-channel, 720p@240/200 fps, 1080p@120/100 fps, 2 SATA, alarm I/O
HRHQ116* HQA DVRS	16-channel, 720p@480/400 fps, 1080p@240/200 fps, 2 SATA, alarm I/O

HOUSING AND MOUNTS		
HQA-PM2**		Pole Mount Adapter
HB34S2-CM**		Corner Mount Adapter
HBS2-BB		Junction Box
HEJB		Junction Box

* Pre-installed storage (TB).

** The HBS2-BB or HEJB junction box must be used when installing the camera to HQA-PM2 or HB34S2-CM.

TDN 1080p IR Bullet Cameras

ORDERING

HB30XD2	TDN 1080p IR Bullet Camera, 1/2.9" 2 MP CMOS, 3.6 mm Fixed Lens, 18 IR LEDs, 12 VDC, IP66
HB41XD2	TDN 1080p IR Bullet Camera, 1/2.9" 2 MP CMOS, 2.7–13.5 mm Vari-focal Lens, 20 IR LEDs, 12 VDC, IP66

DIMENSIONS

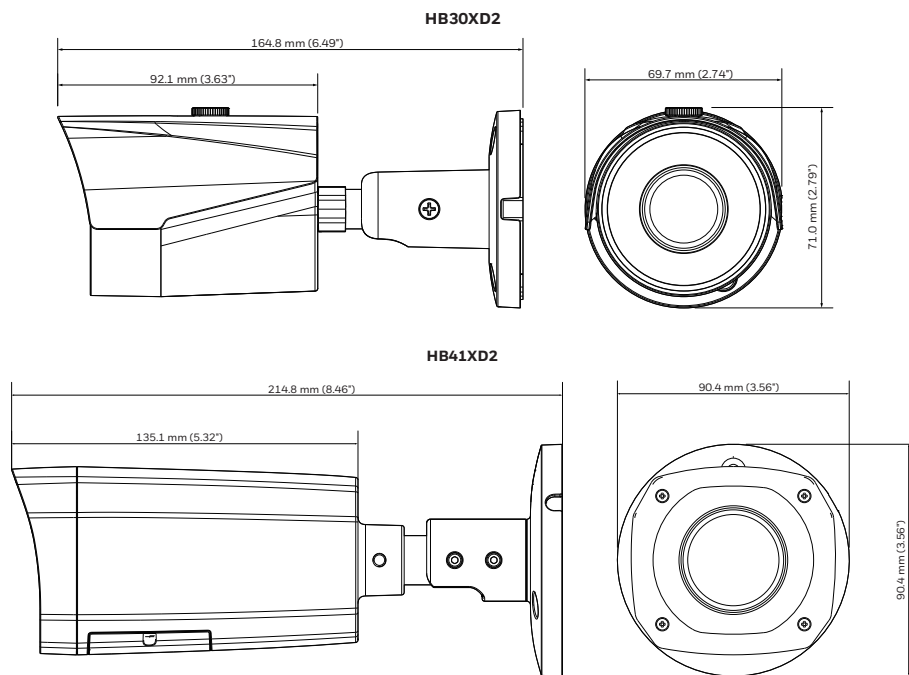

For more information

www.honeywell.com/security

Honeywell Security and Fire

Aston Fields Road
Whitehouse Industrial Estate
Runcorn, Cheshire, WA7 3DL
United Kingdom
Tel: +44 (0)8448 000 235
www.honeywell.com

Honeywell Security Office -

Emaar Business Park, Sheikh Zayed Road
Building No. 2, 2nd floor, 201
Post Office Box 232362
Dubai, United Arab Emirates
Tel: +971 44541704
www.honeywell.com

Honeywell reserves the right, without notification, to make changes in product design or specifications.

HSFV-HB30XD2D-01-UK(0917)DS-E
November 2017
© 2017 Honeywell International Inc.

Honeywell