

ADDRESS PROGRAMMER



Model TCH-B100 is a hand held address programmer designed to address the ESP range of Products.

The unit is designed to be light, robust and easy to use and operates from a single PP3 size Battery, which gives the capacity for up to 8000 operations, the programmer is also capable of displaying the sensor analogue values.



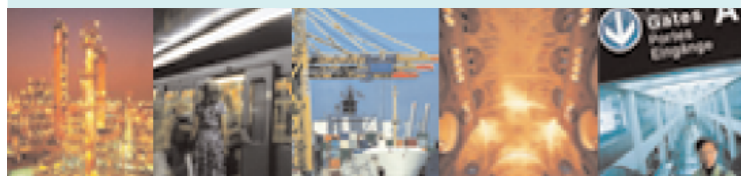

- ▶ Lightweight Design
- ▶ Quick and Reliable Addressing
- ▶ Over 8000 Address Settings From One Battery
- ▶ Displays Sensor Analogue Value

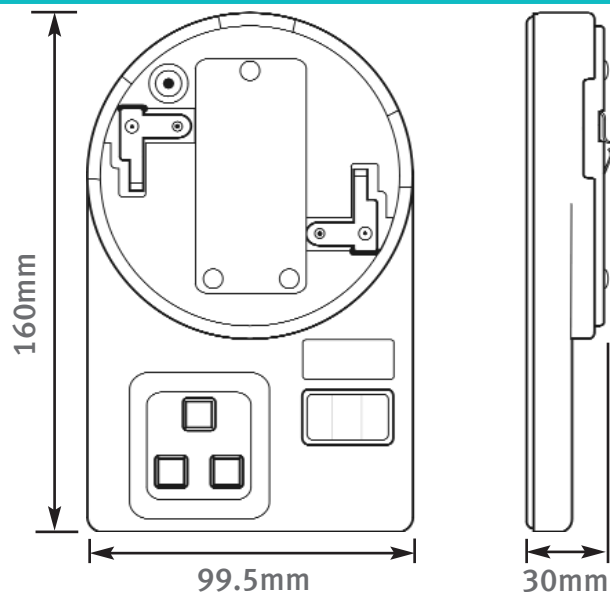

DIMENSIONS

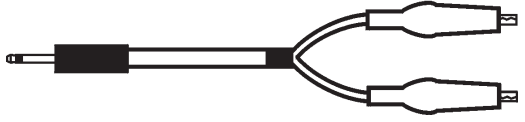

PROGRAMMING LEADS

- PL-1**  Programming Lead for use where the device cannot be fitted directly onto the programmer
- PL-2**  Programming Lead for use where the device cannot be fitted directly onto the programmer
- PL-3**  Programming Lead for use with devices featuring a programmer connector

SPECIFICATION

Ordering Code	TCH-B100
Battery Type	9Vdc (PP3 type)
Operating Temperature Range	-10°C to +50°C
Colour / Case Material	White / ABS
Weight (g)	140 (Including Battery)

HOCHIKI EUROPE (UK) LIMITED
Grosvenor Road, Gillingham Business Park,
Gillingham, Kent, England ME8 0SA
Telephone: +44 (0)1634 260133
Facsimile: +44 (0)1634 260132
e-mail (UK): sales@hochikieurope.com
e-mail (Non UK): export@hochikieurope.com
www.hochikieurope.com

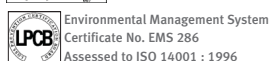

Hochiki Europe (UK) Ltd. reserves the right to alter the specification of its products from time to time without notice. Although every effort has been made to ensure the accuracy of the information contained in this document it is not warranted or represented by Hochiki Europe (UK) Ltd. to be a complete and up-to-date description.

PART No. 9-5-0-260/ISS1/OCT04